

## INSTALLATION

1. Making sure that the clamp frame is not yet removed (to stop debris from entering the sliding mechanism), set access cover assembly into floor structure ensuring that item is centred over the "Clear Opening", as shown above and that the direction of cover opening (see label affixed to cover) is appropriate to the place of installation.
  2. To fit vinyl, remove clamp frame from assembly.
  3. Remove clamp strips from outer frame & dress vinyl into frame, as per vinyl manufacturer's instructions, ensuring the vinyl is suitably adhered & there are no "ridges" present.
  4. Re-fit clamp strips onto frame, ensuring vinyl is held in place.
  5. Using lifting mechanism provided (see operating instructions on sheet 2), slide the cover to one side.
  6. On the cover, remove the clamp strips & dress vinyl onto cover as per vinyl manufacturer's instructions, ensure that the vinyl is suitably adhered & there are no "ridges" present.
  7. Re-fit clamp strips onto cover, ensuring vinyl is held in place.
  8. Carefully slide & lower the cover back into the frame & tuck handles back in.
  9. Place clamp frame back in position & re-fit screws.
- (We suggest the screws are all fitted loosely to allow for slight adjustment, prior to screwing down fully)

© 2014

ISS. No.	2		DRAWN	DC	27-1-14	TITLE TYPICAL INSTALLATION OF STAINLESS STEEL SHEET VINYL SLIDING ACCESS COVERS		
C.N. No.			CHECKED					
DATE	1-7-14		APPRVD.					
		MATERIAL	50910054			SCALE NTS	DRG. No. <b>INSTAL 56</b> SHEET 1 OF 2	ISSUE No. 2

WADE INTERNATIONAL LTD., THIRD AVENUE, HALSTEAD, ESSEX, CO9 2SX.

TEL: 01787 475151 FAX: 01787 475579

e-mail: tech@wade.eu web site: www.wade.eu

**OPERATION OF SLIDING COVER**

1. Remove screws from clamp frame.
2. Remove clamp frame & set aside.
3. Note position of handle in Fig 1.
4. Rotate handle to position in Fig 2.
5. Extend handle as shown in Fig 3.
6. Rotate extended handle as shown in Fig 4 ensuring wheel arm is fully extended.
7. Go to opposite end of cover, using wire handle (see Fig 5) lift & slide cover along to expose access space.
8. To close cover, reverse above.

FIG. 1

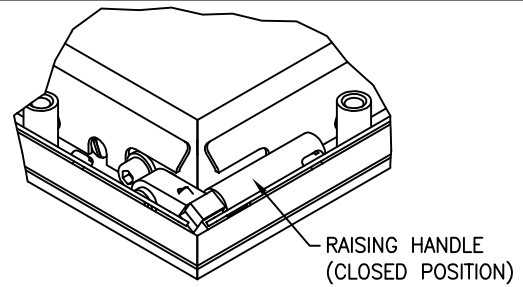

FIG. 2

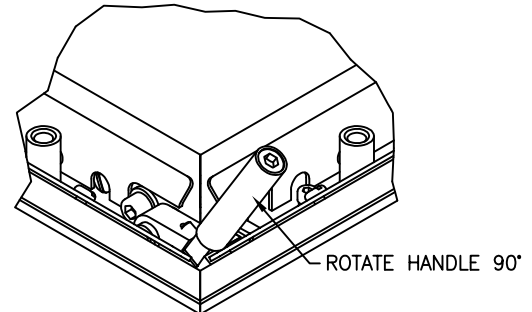

FIG. 3

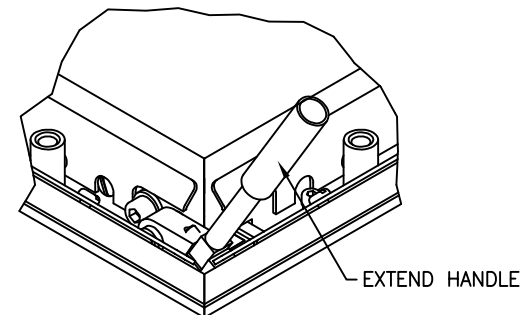

FIG. 4

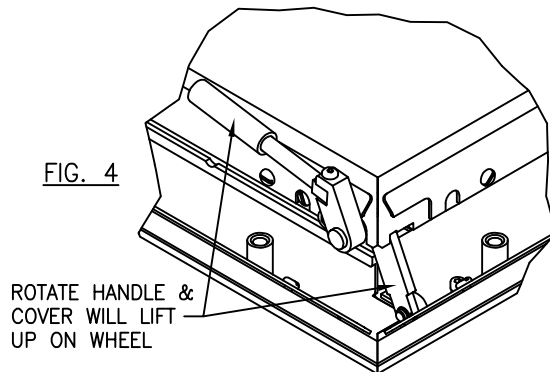
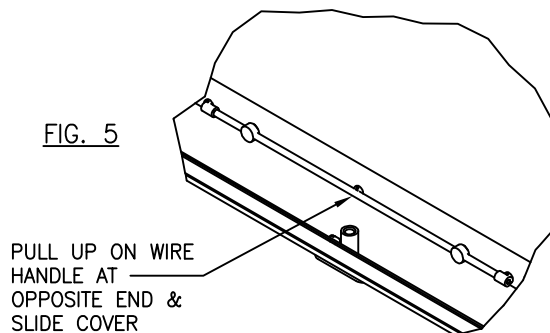



FIG. 5



© 2014

ISS. No.	2		DRAWN	DC	27-1-14	TITLE TYPICAL OPERATION OF STAINLESS STEEL SHEET VINYL SLIDING ACCESS COVERS		
C.N. No.			CHECKED					
DATE	1-7-14		APPRVD.					
		MATERIAL	50910054			SCALE NTS	DRG. No. <b>INSTAL 56</b> SHEET 2 OF 2	ISSUE No. 2

WADE INTERNATIONAL LTD., THIRD AVENUE, HALSTEAD, ESSEX, CO9 2SX.

TEL: 01787 475151 FAX: 01787 475579  
e-mail: tech@wade.eu web site: www.wade.eu