

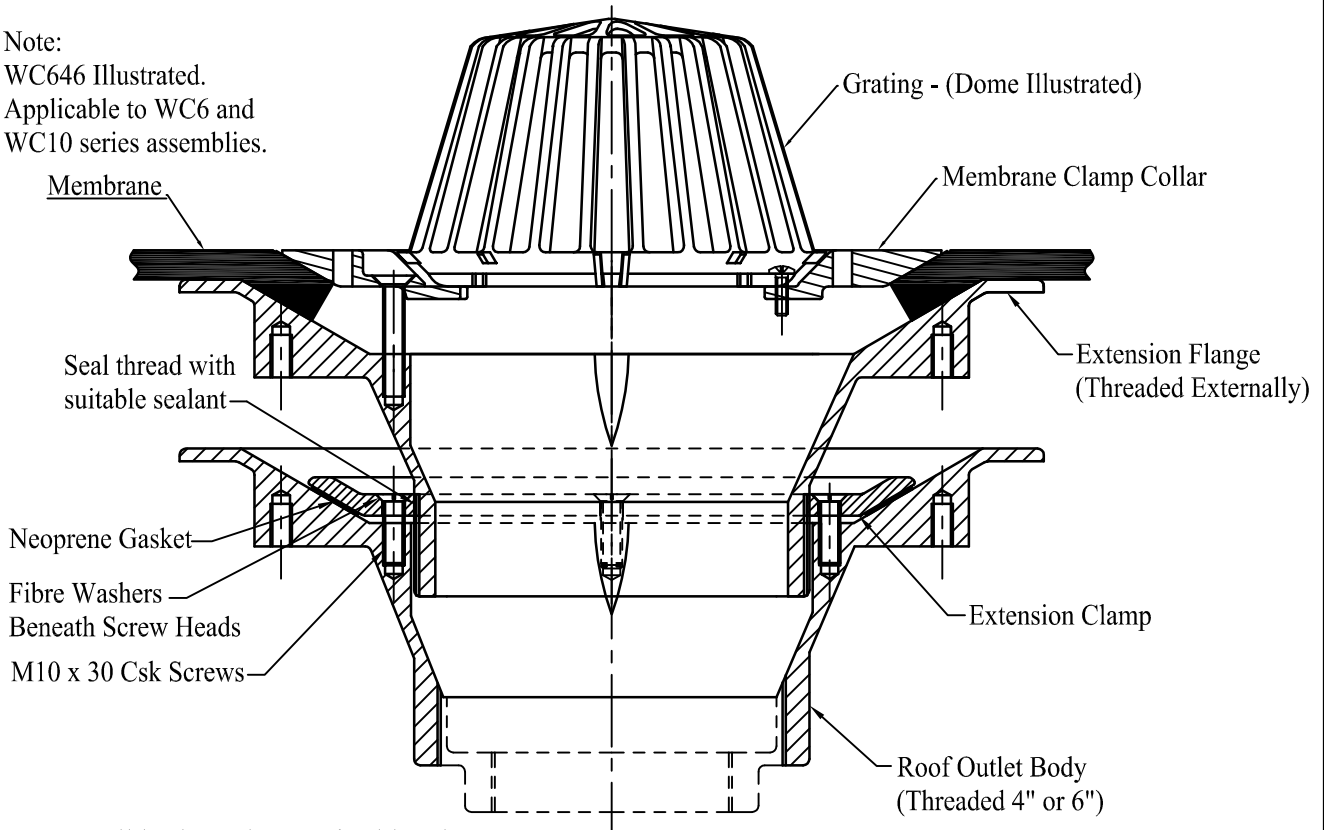

Note:
WC646 Illustrated.
Applicable to WC6 and
WC10 series assemblies.



1. Install body at the required level
2. If vapour barrier/secondary membrane is fitted at body level it may be dressed over the body flange and into the body such that it will be clamped by the extension clamp when fitted.
3. Fit extension clamp using 3 off M10 x 30 csk slotted screws ensuring that;
 - a. the neoprene gasket is fitted below clamp.
 - b. the fibre washers are fitted under the screw heads.
4. Fit extension flange into extension clamp. Adjust to required height and seal thread with a suitable sealant.
5. Taking the fished application into consideration ensure that the extension flange is appropriately supported to prevent movement.
5. Extension flange is now ready to accept membrane / grating assembly.
6. Refer to membrane manufacturer's instructions and prepare flange with suitable primer. Apply membrane, dressing over flange sufficiently into sump of body to enable it to be clamped. Position membrane clamping collar and secure to body using appropriate supplied fixings, see below.
For membranes up to 15mm thick - use M10 x 30 Countersunk head screws (Wade Pt No 50902073)
For membranes over 15mm thick - use M10 x 50 Countersunk head screws (Wade Pt No 50902077)
7. Fit grating to membrane clamping collar.

See also the general installation guidelines in Wade 'Roof Outlets' Brochure.

© 2011

ISS. No.	5		DRAWN	DC	16-2-11	TITLE GENERAL INSTALLATION DETAIL FOR WC6 AND WC10 SERIES ROOF OUTLETS	
C.N. No.	4940		CHECKED				
DATE	21/7/16		APPRVD.				
		Part Number 50910025			SCALE NTS	DRG. No. INSTAL 26	ISSUE No. 5

WADE INTERNATIONAL LTD., THIRD AVENUE, HALSTEAD, ESSEX, CO9 2SX.

TEL: 01787 475151 FAX: 01787 475579

e-mail: tech@wade.eu website: www.wade.eu