

Installation guidelines

General installation guidelines are provided for gully components in a tiled finished floor with a damp proof membrane. Page 3SF gives additional guidelines for installing gratings designed for use with sheet flooring finishes, such as vinyl. See also wade.eu/installation

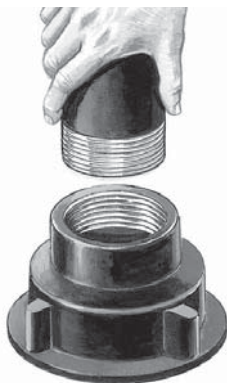

1. Where applicable, screw spigot adaptor into the body outlet using a suitable sealant to ensure the joint is watertight.

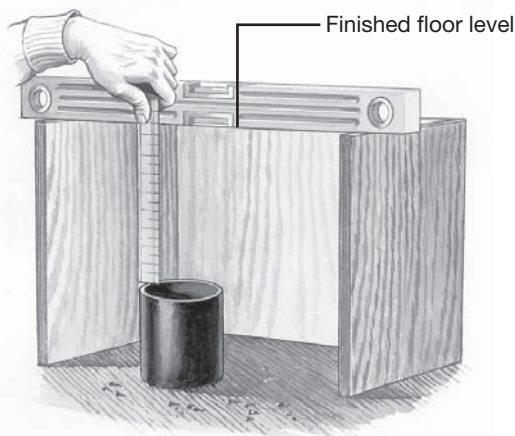

2. Measure the distance between the top of the connecting pipework and finished floor level.
3. Check that this distance will enable the complete gully (with extensions, if applicable) to be installed with the top face of the grating or cover flush and level with the finished floor.

Note

Where a damp-proof membrane is used, the body must be installed with the top of the flange at or below membrane level.

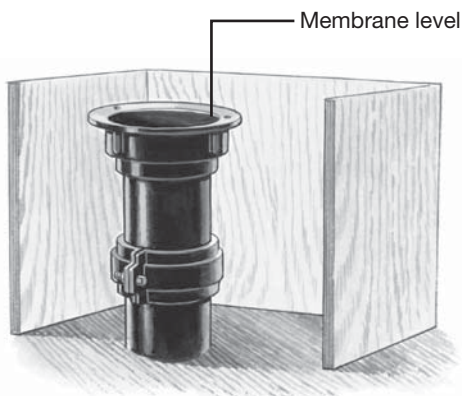

4. Connect body (with spigot adaptor if applicable) to pipework.
5. Infill as required.

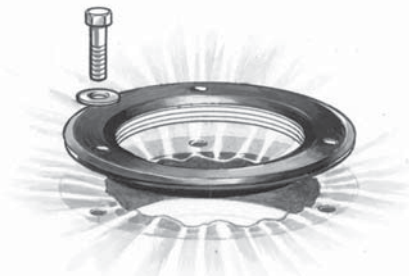

6. Where applicable, dress the membrane over the flange and into the sump of the body, ensuring that the membrane does not restrict the outlet; bolt the membrane clamping collar to the body – certain collars are reversible to increase height adjustability.

Note

In some cases the membrane clamping collar serves to connect the grating or cover to the body, so it must be fitted even where a membrane is not used. In installations without a below-floor membrane and/or using sheet floor covering such as vinyl, the membrane clamping collar should be sealed to the body using the supplied gasket and, where supplied, fibre washers beneath the screw heads.

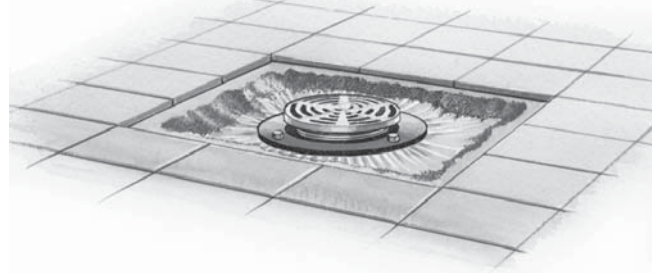

7. Fit grating, cover, or funnel with extensions, frame or collar as applicable; set top face flush and level with the finished floor using height adjustability features. Use a suitable, good quality sealant on all threaded joints to ensure a watertight assembly.

All joints need to be sealed to ensure that leaks do not occur in the event of water backing up in the gully, e.g. if a downstream pipe blockage occurs. The exception is gully assemblies specified with weepholes, which are designed to provide supplementary drainage from above the membrane; these weepholes should not generally be sealed.

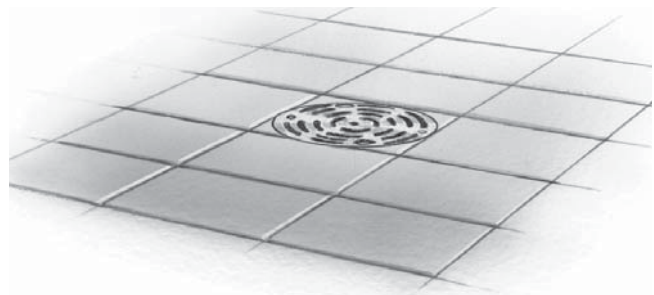

8. Infill or lay floor screed and apply final floor finish (e.g. tiles, marble, paviers, terrazzo) around the grating or cover.

Note

Installation of gratings and covers for use with sheet floor covering, such as vinyl, is illustrated on page 3SF.

Installation guidelines

Gratings and access covers for use with sheet floor covering

Worldwide demand for higher standards of hygiene and safety in buildings is reflected in the increasing use of modern slip-resistant flooring. In keeping with its position at the forefront in the design and manufacture of gullies, Wade has developed a range of superbly finished products specifically for use with flexible sheet floor covering such as vinyl. Where a clamping collar is fitted a watertight seal is obtained, yet gratings and covers are removable for access to pipework without disturbing the flooring material. See also www.wade.eu/installation

G202

Cast iron body with K2302 nickel bronze grating.



Typical installation in a wooden floor.

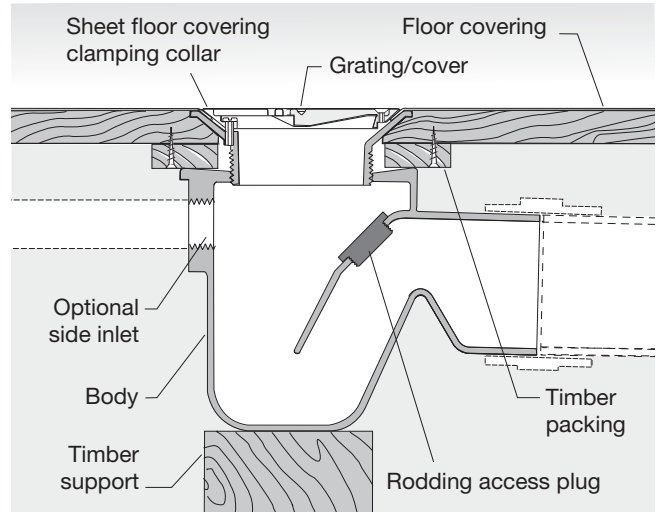

N213

Nickel bronze grating, with cast iron backnut, connected directly to 40mm plastic pipework.

Watertight drainage in a vinyl covered timber floor.

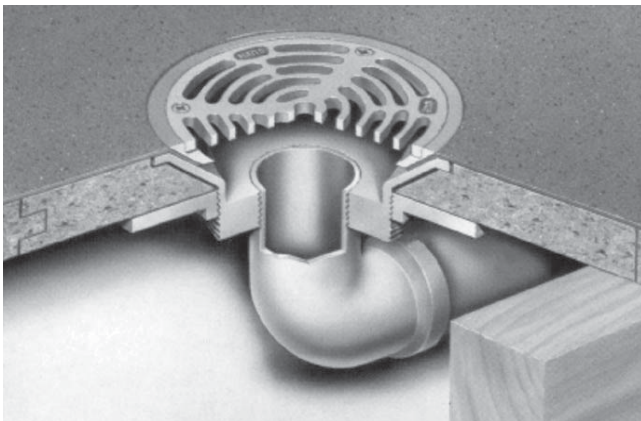

Typical installation with damp-proof membrane.

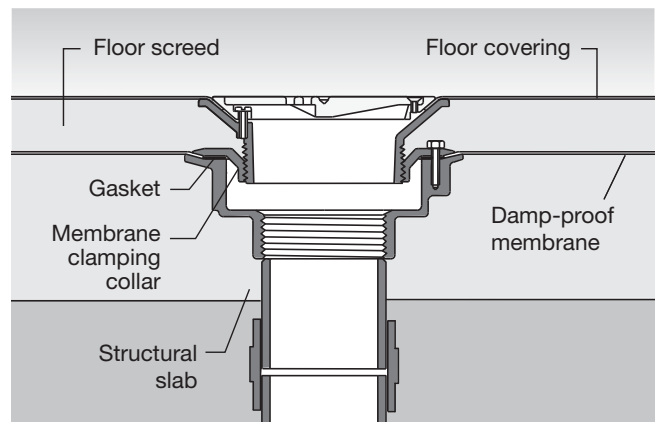

To achieve a watertight joint, installation must be in accordance with instructions which accompany the gratings/covers.

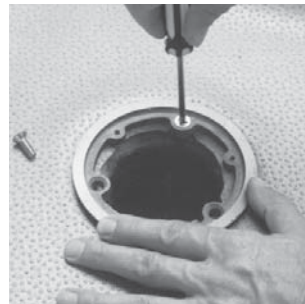
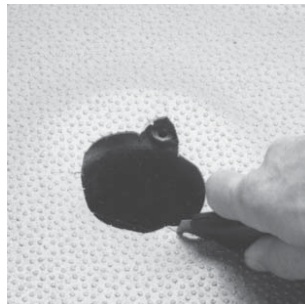
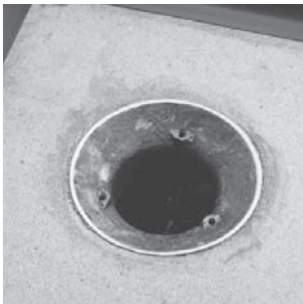

C, D, GC, GD & GP SERIES BODIES

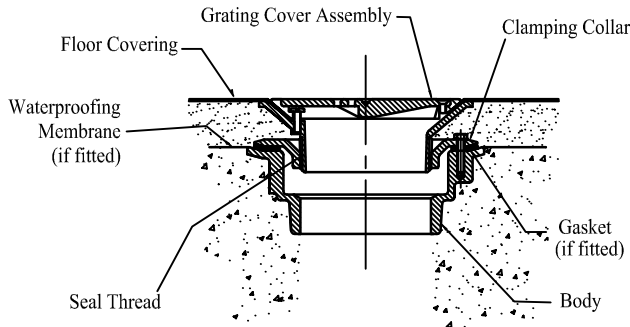

1. Ensure Correct Clamping Collar is used

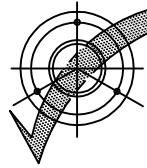

Use Clamping Collar With 3 Holes

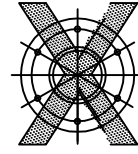

Do not use Clamping Collar with 6 Holes

2. Ensure Gasket is fitted between Clamping Collar & Body

3. Seal Height Adjuster Thread with suitable compound after setting grating/cover assembly to required height.

H & J SERIES BODIES

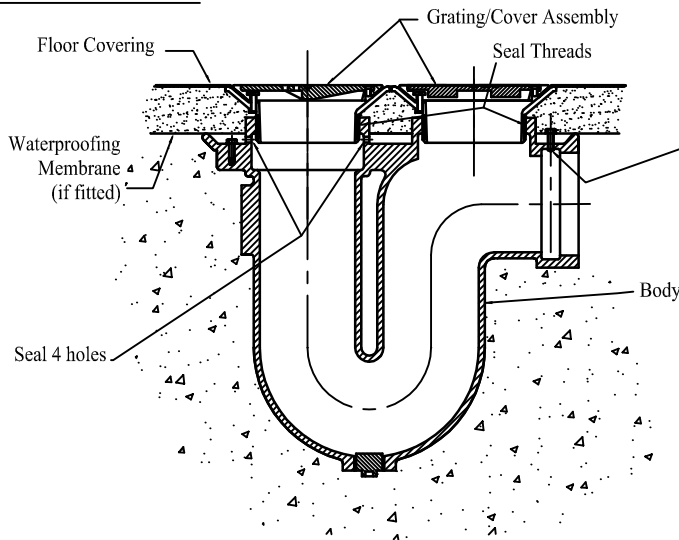

If waterproofing membrane clamp is not fitted then the tapped holes within the body must be sealed with mastic.

1. The 4 holes equi-spaced around the neck of the body should be sealed with mastic. (see illustration)

2. Seal height adjuster threads with suitable compound after setting grating/cover assembly to required height.

B & G SERIES BODIES

If waterproofing membrane clamp is not fitted then the tapped holes within the body must be sealed with mastic.

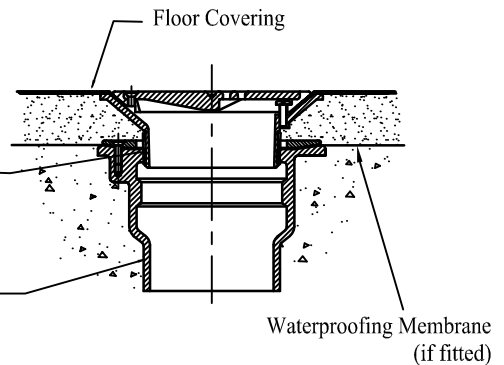
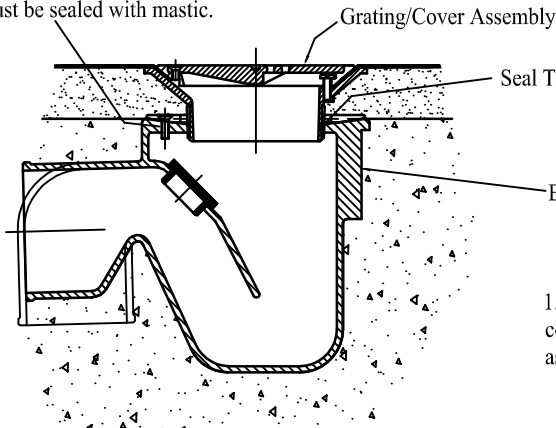

1. Seal height adjuster thread with suitable compound after setting grating/cover assembly to required height.

TITLE	DRG No.	ISS No
50910020	INSTAL 2 SHEET 1 OF 2	7

INSTRUCTIONS FOR USE WITH ABS GULLY NON-VARI LEVEL

Concrete/Screed Floor

Timber Deck Floor

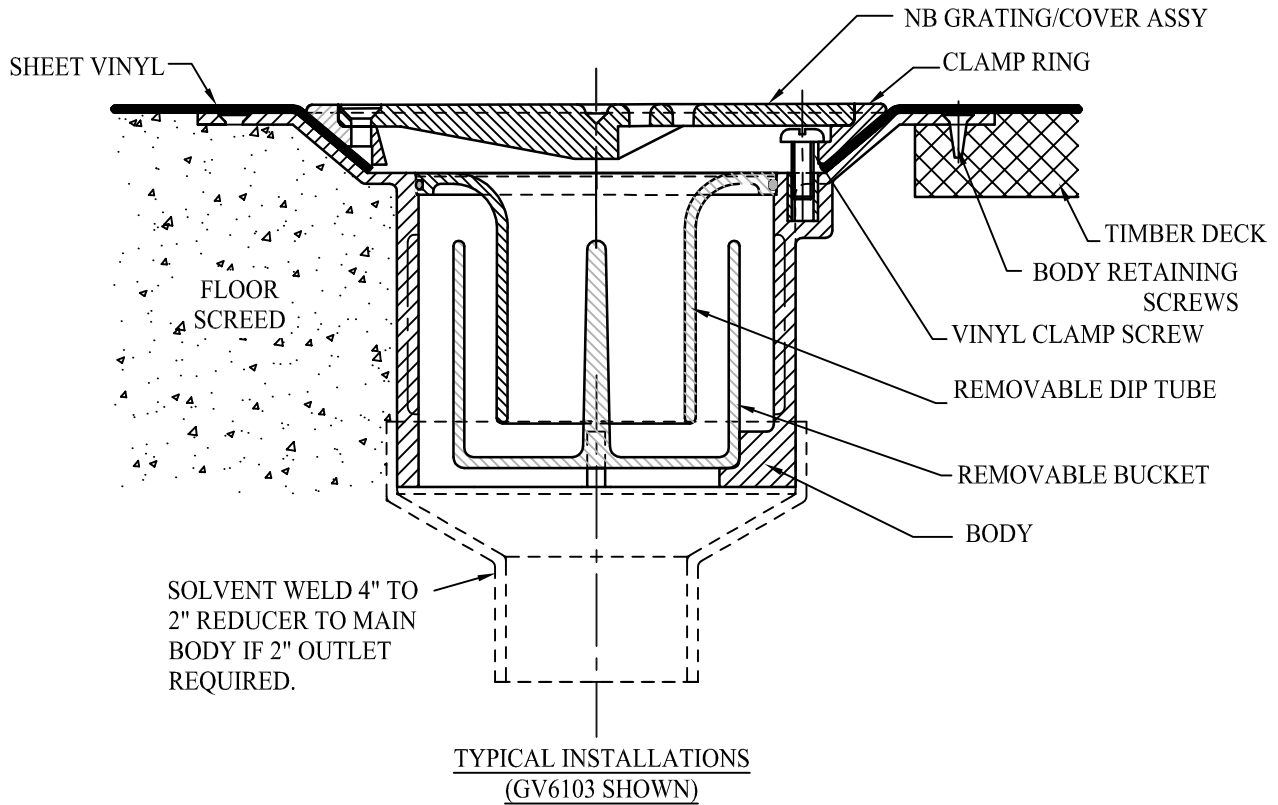

The body must be adequately supported such that the top face of the GV series body flange will finish flush with the top face of the timber deck or concrete screed/slab.

Installation in Concrete/Screed Solid Floors (Drawing L/H Side)

Install the body as shown in the drawing. Position assembly and pour screed to secure.

Installation in Timber Deck (Drawing R/H Side)

Take a suitable sized section of floor timber and cut a hole $\text{Ø}175$ through to accept the body, then rebate $\text{Ø}220$ to depth of flange. Install the body as shown in the drawing. Position and fix complete assembly onto floor joists.

It is essential that the gully flange and body are fully supported in all applications.

Make pipework connection and test for leaks.

Applying sheet floor covering.

Dress sheet vinyl covering such that it does not extend beyond the sloping face of the body/vinyl clamp. Remove the grating/cover from the clamp ring assembly. Fit the clamp ring in the body using the 3 screws provided. Refit the grating/cover into the clamp ring.

© 2011

ISS. No.		DRAWN	DC	24-1-11	TITLE INSTALLATION GUIDELINES FOR GV SERIES GULLY		
C.N. No.		CHECKED					
DATE		APPRVD.					
	MATERIAL	50910020			SCALE NTS	DRG. No. INSTAL 2 SHEET 2 OF 2	ISSUE No. 7

WADE INTERNATIONAL LTD., THIRD AVENUE, HALSTEAD, ESSEX, CO9 2SX.

TEL: 01787 475151 FAX: 01787 475579

e-mail: tech@wade.eu web site: www.wade.eu